

Integrating Alternative Power in Maritime Systems

Matteo Sartori – Team Leader, System Development & Design

6th October 2025

Main Engine + e-Machine + Battery

“

Hybrid [haɪ.bɹɪd]

Something that is formed by combining two or more things

”

Ship Owner + Market + Lawmakers

Technical + Procurement + Operations

Equipment + Infrastructure

Ship + Fleet

Newbuild + Retrofit

Evolutionary + Revolutionary

Ship Owner + Ship Designer + Ship Yard + OEMs + Integrator

Wärtsilä Portfolio for a Hybrid Approach to Decarbonisation

Reduce the demand of energy

- Energy Saving Devices
- Voyage Optimisation

Transform energy more efficiently

- Advanced Combustion
- Hybridisation
- Electrification

Use alternative sources of energy

- Shore Connection
- Alternative Fuels

Wartsila is a leading global marine electrical system integrator



Shaft generator systems (1000 vessels)



Diesel-electric propulsion (400 vessels)



Hybrid propulsion (400 MWh batteries)



Full electric ships
(largest and fastest vessels)

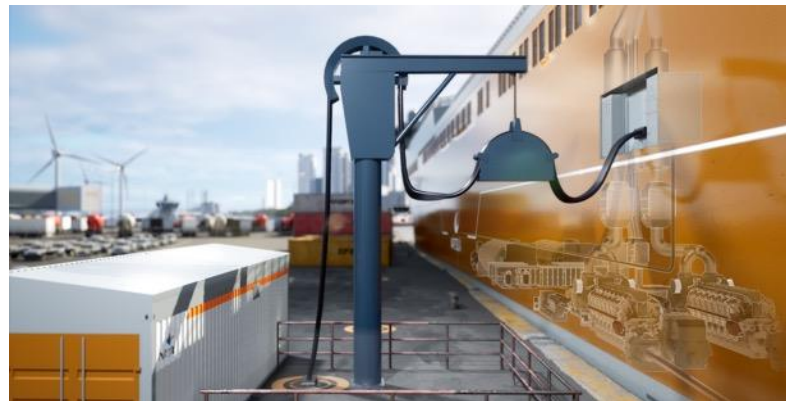

Shore power (150 vessels)

Newbuild solutions

Retrofit solutions

Lifecycle services

Two shore power routes exist today

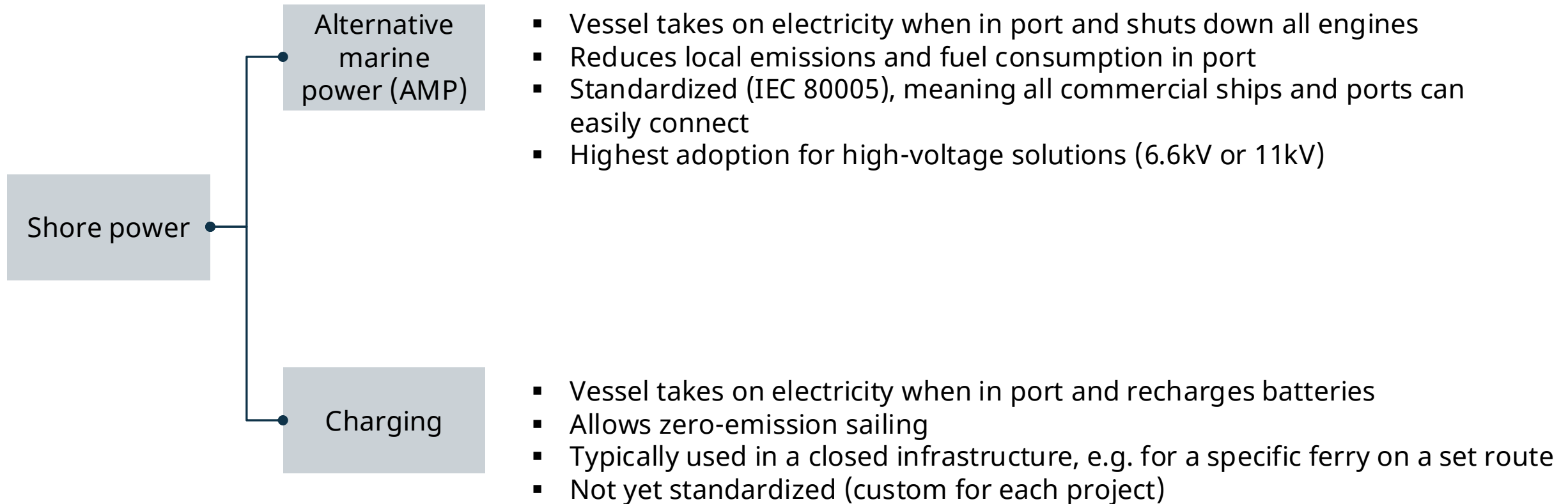

An IEC connection can be used for charging e.g. a RoPax ferry



Molslinjen
Pure Electric high-speed catamaran



Isle of Man Steam Packet Company
Electric Hybrid - Diesel



STENA/Marine Atlantic
Mechanic Hybrid - Gas



EXPERIENCE FROM PURE ELECTRIC FERRY TO THE LARGEST HYBRID ROPAX



Balfour ferry, western pacific
Electric Hybrid - Diesel



Finnlines
Mechanic Hybrid - Diesel



STENA/Brittany Ferries
Mechanic Hybrid - Gas

Medstraum Ferry

Vessel runs in fully electric mode between Stavanger and the outer islands

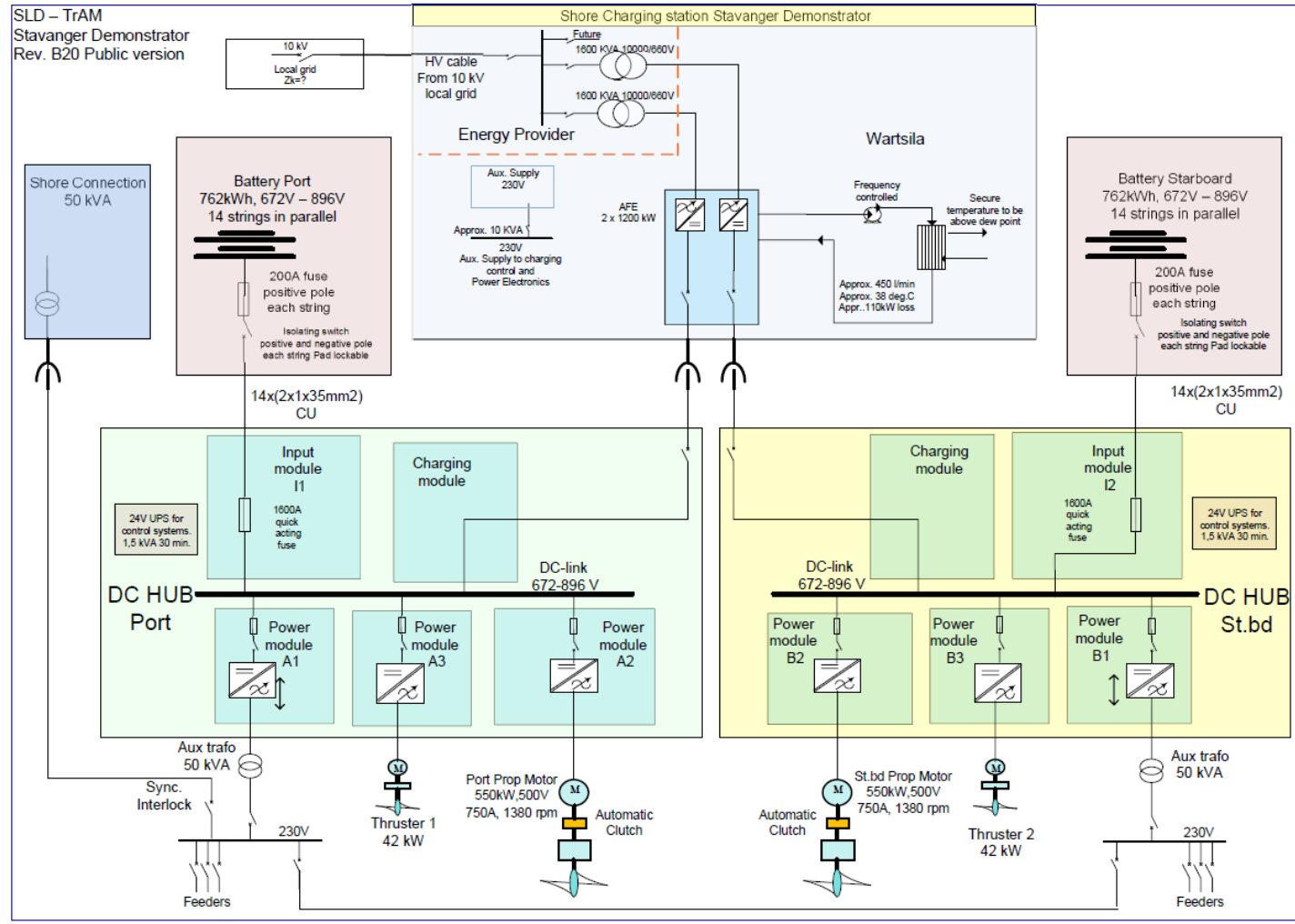

- Cruising speed during operation: 23kn, max speed: 27 kn
- Length: 30 meters. Width: 9 meters.
- Battery capacity: 1524 kWh
- Electric motors: 2× 550 kW
- Charge capacity: 2,3 MW via 6 CCS chargers



The biggest battery electric ship ever built has Wärtsilä integrated solution on-board and on-shore

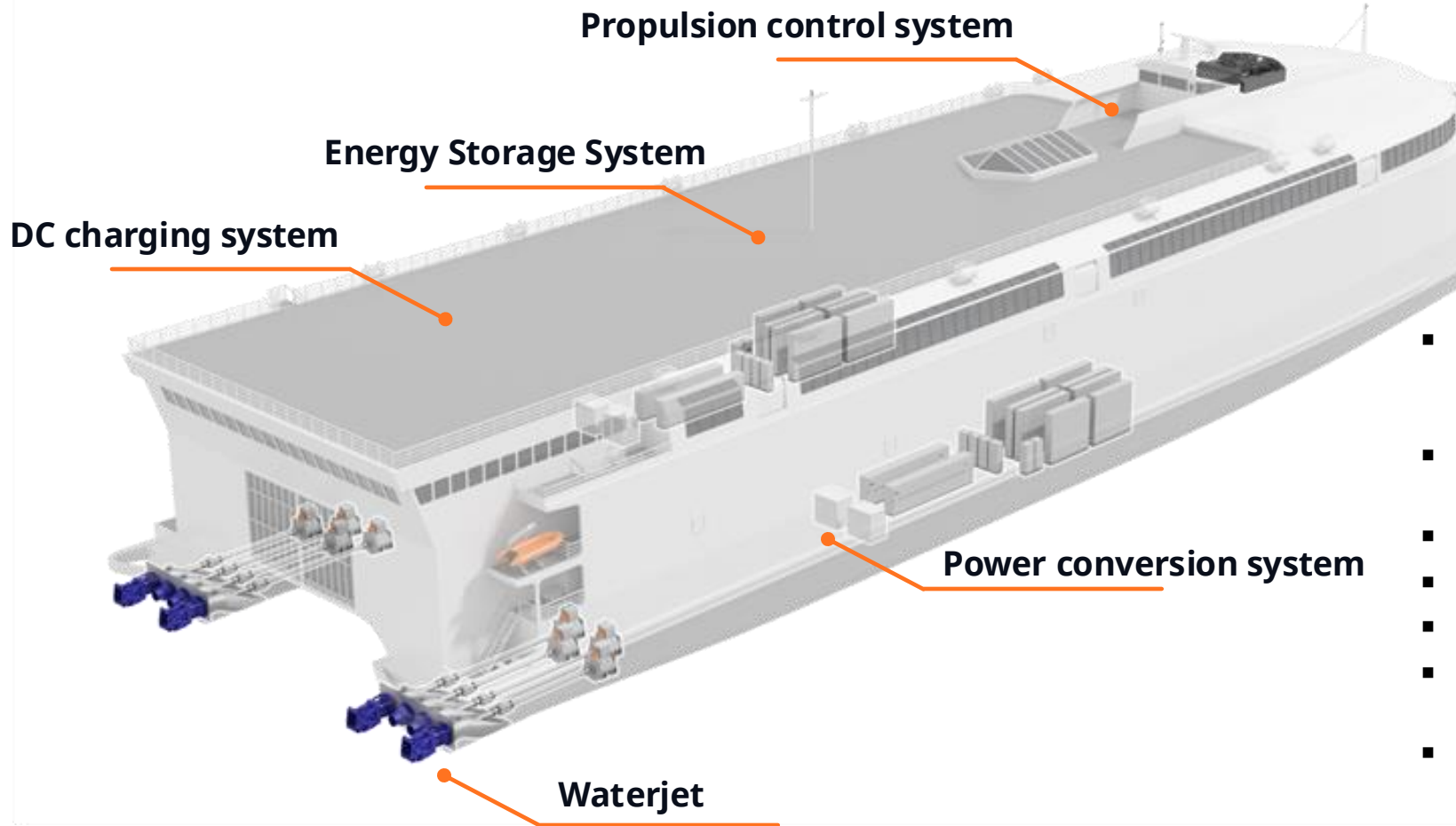

- 130m LOA, capacity up to 2100 Passenger and crew, 225 cars and over 2000 Sqm of duty free shops
- Lightweight high speed aluminum catamaran
- Cruise speed 25 knots
- 1.5 h sailing, 1.5h charging (~20 MWh)
- 41MWh battery
- 8 x permanent magnet electrical propulsion motors, 2200kw (peak 2400kW)
- 4 DC Hubs plus battery short circuit limiters
- 2 x high speed Charging connectors, 15MW

Large RoPax case



STENA/Brittany Ferries Mechanic Hybrid - Gas

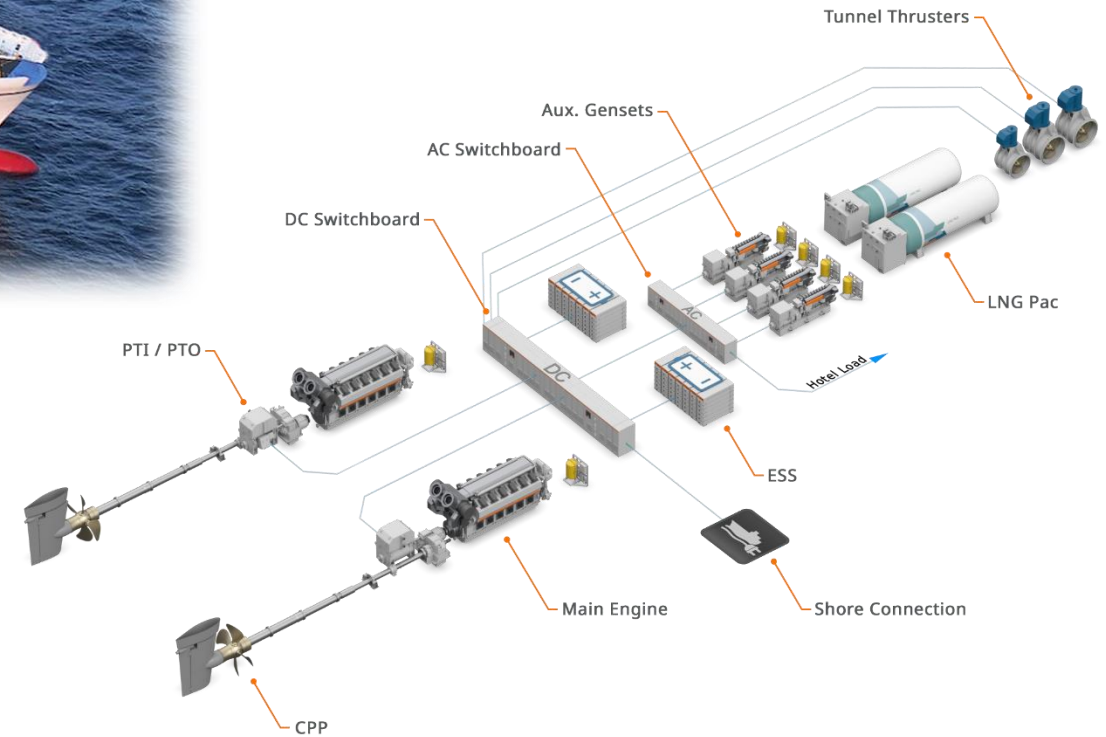

Zero emission in harbour area



Approaching & Leaving

Maneuvering

Port stop with shore connection or on ESS w/o shore connection

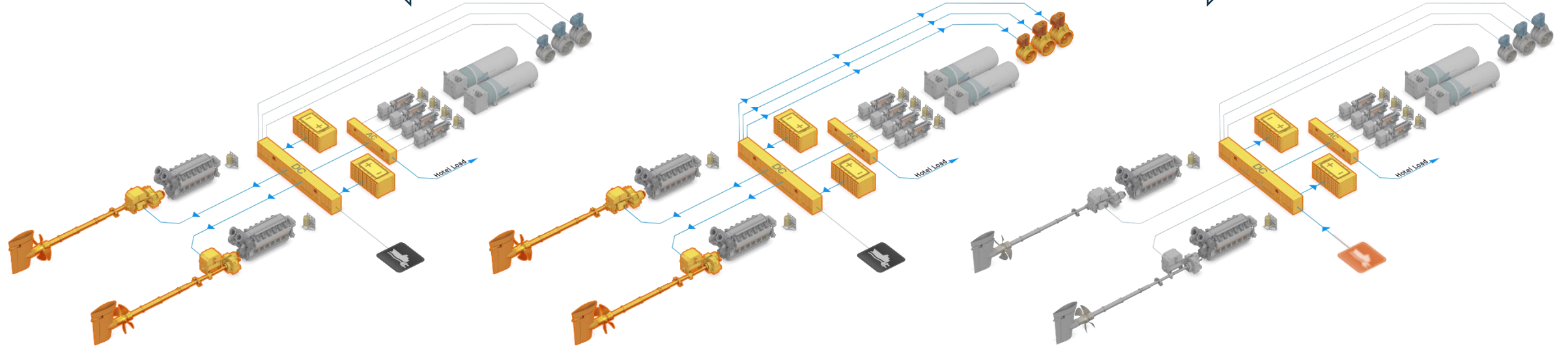

Not only new-building



- Retrofit to sail 45min full electric at 15min charging > 20 times a day
- Battery and power conversion below deck



- Optimized fuel efficiency
- Increased zero emission operations capabilities using green power from shore

Integrated Systems and Solutions

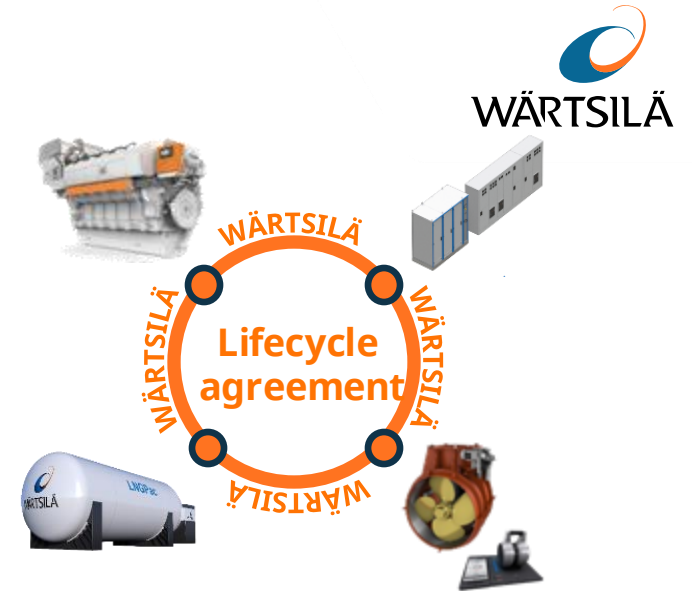
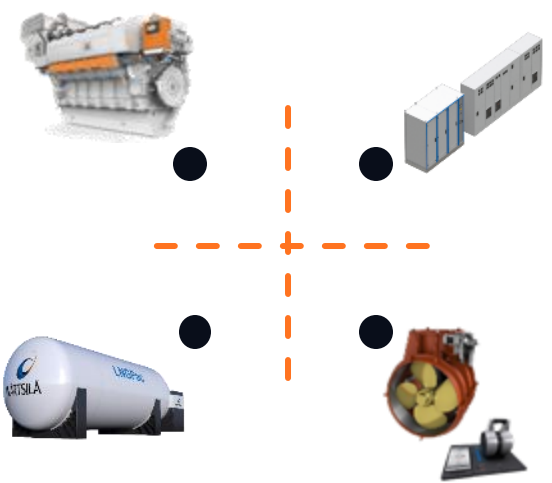

Product Delivery
Ensuring that the Wärtsilä equipment is delivered according to the agreed schedule, quality and budget.

Wärtsilä responsibility and commitment

Integrated Solution Project
Ensuring that the Wärtsilä Solution project is integrated to the customer's overall project and targets – supporting the success.



WÄRTSILÄ